



AMI

Oxygen Analyzer Manual

Model 70R1



AMI, Costa Mesa, CA

Contents

Preface	1
The AMI story	1
Caution	1
Address	1
Model 70R1 Oxygen Analyzer	2
Introduction	2
Features:	2
Oxygen sensor:	3
Receiving the analyzer	3
Important:	4
-----Points to consider first! -----	4
Installation and Operation	6
Receiving the analyzer	6
Installation	6
Location:	6
Short-form Installation Procedure	7
Laptop set up procedure:	8
Detailed Analyzer Description	10
Calibrate (“Span”) the analyzer:	11
Reading display:	11
Analog output:	11
Alarms:	12
Digital outputs:	12
Alarm Bypass:	12
Up button - Span Factor:	12
Down button – Temperature reading:	13
Interconnections:	14
Alarm connections:	14
Output connections:	15
Serial connections:	15
Sample Handling:	15
Maintenance and troubleshooting	16
Maintenance:	16
Periodic Calibration:	16
Sensor Replacement:	16

Troubleshooting	17
All oxygen applications	17
Specifications and Disclaimer	19
Specifications:	19
Disclaimer	20

Preface

The AMI story

The AMI series of analyzers provide the latest in high-definition oxygen analysis. The series includes trace (ppm) and percent models in several configurations. All of them share the same basic design approach, using state-of-the-art oxygen sensors and advanced high definition electronics for noise and interference free performance.

Please verify that the analyzer was not damaged in transit. If so please contact the shipper as well as AMI.

Caution

Read and understand this manual fully before attempting to use the instrument. In particular understand the hazards associated with using flammable or poisonous gases.

Address

Advanced Micro Instruments

225 Paularino Ave

Costa Mesa, CA 92626

(714) 848-5533

www.amio2.com

Last Revised: 02/21/2023
OM-300-001 Rev C

Model 70R1 Oxygen Analyzer

Introduction

The Advanced Micro Instruments Oxygen Analyzer Model 70R1 provides the latest in high precision oxygen measurement. It is designed for monitoring oxygen in percent ranges in a non-hazardous area.

This manual is divided into two major sections: a quick reference section for experienced users, and a general explanation for all users.

This manual covers firmware version 2.0.

Features:

- Compact size
- Auto-ranging display with user-selectable output range
- Three customer-selected levels of security access settable via the USB interface.
- Optional air or span gas calibration, no zero gases required
- Suitable for use with non-flammable gases only
- High accuracy and fast response
- Large liquid crystal display
- Standard isolated 4-20mA output
- Two fully adjustable alarm relay contact closures 24VDC/230VAC 5A.
- User configurable alarm delays
- User selectable pulse drivers for latching-type solenoid valves
- Orifice flow control for use with medium pressure samples
- Built-in data logging with real time clock
 - Logs oxygen, temperature, power supply voltages
- Automatic logging of low power, start up and calibration events
- USB connection for AMI provided software
- RS485 connection for ModBus™
- 12-24VDC operation

Oxygen sensor:

The model 70R1 uses a state-of-the-art zirconium oxide sensor. This sensor provides unmatched stability, and is virtually unaffected by temperature changes or barometric pressure changes. It has an expected lifetime of up to ten years of continuous operation. It is suitable for use only with non-flammable gases of similar thermal conductivity to nitrogen – **do not use it with hydrogen, helium, any hydrocarbon gases or Freons or other halogenated hydrocarbons, or mixtures with more than 10% of CO₂, Argon, Xenon or other high molecular weight gases.**

Receiving the analyzer

When you receive the instrument, check the package for evidence of damage and if any is found, contact the shipper.

Important:

This section contains important information to do with safety and installation. Please don't skip it!

-----Points to consider first! -----

Environment – what is the temperature range going to be where the analyzer will be installed? Although the analyzer is insensitive to temperature changes, it should not be operated out of its standard temperature specification of 32°F to 122°F (0°C to 50°C).

Sample conditions – if your sample is hot and wet, you will need to keep water from condensing in the sample line or analyzer. Contact AMI for advice.

Sample pressure – this analyzer is designed to work with medium pressure samples, such as from 1psig to 30psig. As a standard, it contains an orifice which controls the flow over this range. The sensor is not sensitive to flow changes, so the pressure does not need to be controlled within this range.

Power supply – The unit is intended to work with a switching type DC power supply such as a “wall wart”, of somewhere between 12 and 24VDC output.

Electrical connections - Following best electrical practices, run the analog output connections separately from the power and alarm connections. Modbus communications if used should be run with the analog output wiring, using twisted pair wires for both circuits. Run the alarm wires in the same conduit as the power wires.

Span gas – The standard 0-25% unit can be calibrated to ambient air at 20.9% or a suitable span gas can be also be used. A suitable span gas would be a gas with a known percent level of oxygen not exceeding 25% in a balance of nitrogen.

Warm up – this unit takes several minutes to warm up. As it does so at first it will read zero, and then the reading will overshoot the correct value before settling down to an accurate reading. It is best to leave it powered up all the time unless it is not to be used for an extended period of time.

Gases:



Flammable gases – Do not use this analyzer with flammable gases. Not only will it give falsely low oxygen readings (it responds to the “net” oxygen value after any flammable gas has been oxidized) but it may well ignite them.



Halogenated gases (such as Freons) – Do NOT use this analyzer with any such gases. It will cause them to decompose generating highly toxic byproducts such as phosgene.

Installation and Operation

Receiving the analyzer

When you receive the instrument, check the package for evidence of damage and if any is found, contact the shipper.

Installation

Location:

The unit is designed to be mounted in a panel in a general purpose area. It should be mounted at a suitable viewing level. Refer to the drawing (figure 1) showing the analyzer dimensions. It is not suitable for use in a hazardous area.

Although the unit is RFI protected, do not to mount it close to sources of electrical interference such as large transformers, motor start contactors, relays etc. Also avoid subjecting it to excessive vibration – anything worse than a truck may be problematical.

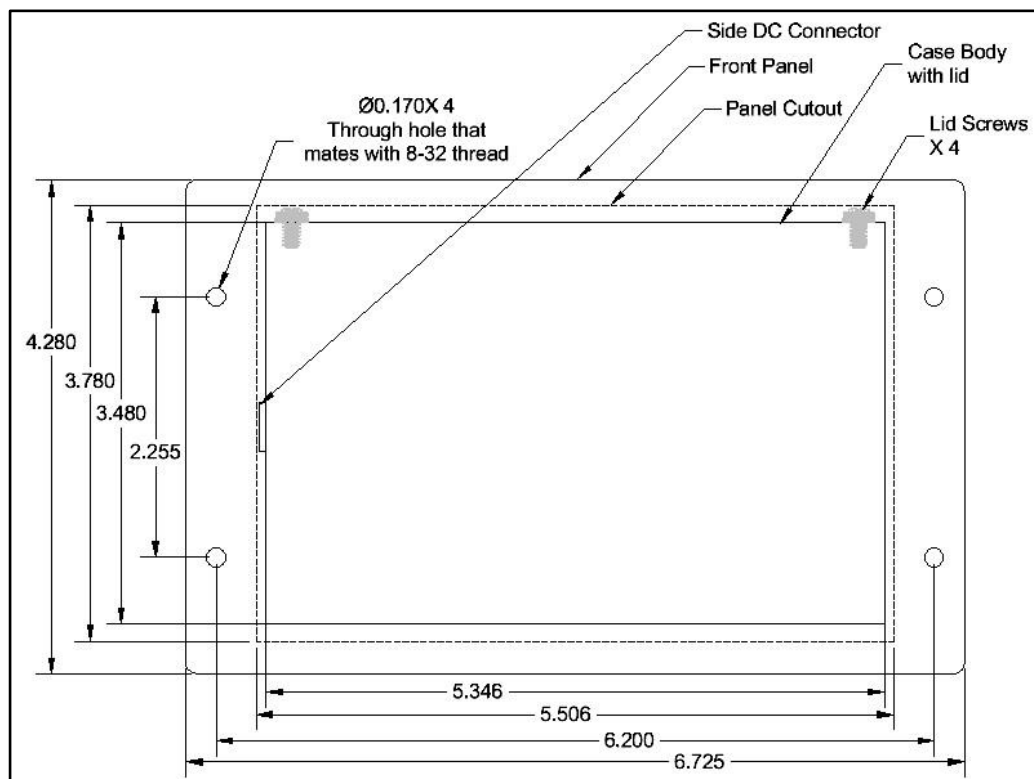

Figure 1. Outline and Cut Out Drawing

Short-form Installation Procedure

1. Mount analyzer at a convenient eye level.
2. Deal with any potential condensation or liquid contamination issues.
3. Connect the sample line to a point close to the sample inlet port with ¼" tubing, either metal or a high quality plastic line. Don't use silicone tubing!
4. Cap the end of the line suitably.
5. Pressurize the sample line to between 1psig and 15psig.
6. Leak check every fitting and weld from the analyzer inlet to the sample tap.
7. Remove the pressure source from the sample line, and remove the cap you just placed on the exhaust of the analyzer. Connect up an exhaust or vent line.
8. Connect the vent line to outside or a suitable purge system, or back into the source if appropriate. Make sure it is at ambient pressure.
9. Connect power, relay contacts, analog output and RS485 if desired. If using conduit, run the power and alarms in one conduit, and the analog output and RS485 in the other.
10. Turn on the analyzer by connecting it to 12-24VDC on the back panel or by plugging in a suitable power supply to the barrel connector on the right side as seen from the back. Only use one or the other of these! If you connect both to separate power supplies, you may damage the analyzer.
11. Wait for about five minutes for the sensor to warm up properly.
12. Verify that you have around 1 SCFH of sample flow with an external flowmeter. The exact flow is not critical, it should be between about 0.2SCFH and 4 SCFH.
13. If you are not using the advanced features, set up the alarms and the output range from the front panel of the analyzer.
14. Optional:
 - a. Connect the laptop, run the User Interface version III and verify all alarm, output and security settings.
 - b. Set the analyzer clock time, and click on "Clear Data Log".
 - c. Verify the output calibration.
 - i. Connect the analog output terminals to an appropriate measuring device – preferably the monitoring device you are going to be using with this analyzer.
 - ii. Arrange that you can readily see the reading given by this device.
 - iii. On the AMI User Interface, check the "Zero" check box under SETUP in the ANALYZER SETUP section.

- iv. Observe the response of the monitoring device, and adjust the number in the Zero box until the monitoring device shows what it considers to be zero (which should correspond with 4mA).
 - v. Check the box marked "Full Scale" in the SETUP section, and adjust the number in the box next to it until the monitoring device shows full scale. This corresponds to 20mA.
 - vi. Check the "Mid Range" box and verify that the monitoring device shows mid scale.
 - vii. Uncheck any boxes (if you forget, the analyzer will revert to its ordinary operation in ten minutes anyway).
15. Test the entire system, including anything controlled by the alarms or analog output, by adjusting the span calibration so as to make the reading go above or below the alarm set points.
 16. If the unit is a 25% one, flow some air through the analyzer.
 17. Adjust span to 20.9%.
 18. (If you are finished with setting it up) remove the USB connection cable.
 19. If desired, span with known calibration gas.
 - a) Connect a regulator to span gas tank.
 - b) Shut off the regulator outlet valve and leak check all the tank fittings, gauges and packing glands with Snoop™ or equivalent liquid leak detector (not spray).
 - c) Connect the span gas to the sample gas inlet.
 - d) Press the ALARM HOLD OFF button, and adjust the time displayed to a suitable value (typically 10 minutes).
 - e) Allow to stabilize for 2-5 minutes.
 - f) Verify that the analyzer reads within about 15% of the span gas value.
 - g) If so, adjust the analyzer span (see below) until it reads the span gas value.
 - h) Let it go back to normal operation (the "SPAN" flag goes out on the LCD display), then press the UP arrow and note the number displayed (the "Calibration factor).
 - i) Turn off the valve on the span gas tank (so it doesn't all leak out).

If the span gas reads worse than 15% wrong, something is wrong either with the gas, or with the plumbing (you have a leak) or some other error. See the troubleshooting section for some ideas about curing this.

Laptop set up procedure:

1. Make sure the laptop has the FTDI driver installed.
 - a. Windows 7 will probably find the driver by itself, but XP probably won't.
 - b. Run the program called CDM20824_Setup.exe which is either in the AMI CD, or can be downloaded from the FTDIchips.com site.
2. Install the AMI program if you haven't done so already.
3. Run the program.
4. On the User Interface screen, at the top, click the "Port" button. Note the ports listed.
5. **Make sure the analyzer is powered up**, and connect the USB cable to it.
 - a. **If you connect the cable without power to the analyzer, the port won't appear.**

6. On the User Interface screen, at the top, click the “Port” button again, and you should see an additional port. Select this port.
7. Let the program figure out how to talk to the analyzer, and watch it load up all the boxes with numbers or words.
8. If you want to name the analyzer, click on the “User ID:” box. A dialog box will come up, asking for a password. Use “AMI” (in capitals) as the password, and then write in up to 12 characters as a name for the analyzer.
9. Set up the output range, that is the range used by the analog output and the alarms to scale the output for your monitoring device.
10. Make sure the security settings are the way you want them.
11. Go through the analog output calibration procedure if desired.
12. Set up the alarms to work as you desire – see the alarm section below for details.
13. Check the analyzer date and time is correct (we set it up for Pacific Standard time, which may not be correct for you). You can send the computer time to the analyzer by clicking the Set Analyzer Time button.
14. Clear the stored data by clicking the “Clear Data” button in the DATALOG section on the right.

Detailed Analyzer Description



Figure 2. The 70R1

Since this analyzer does not contain a replaceable sensor, only electronic controls are visible on the front panel.

Gas flows into the inlet port on the back panel, through an orifice which effectively controls the flow, past the sensor and out of the exhaust.

The sensor technology used is "Zirconium Oxide", so called. This in fact is the same as that used in automobiles to control their combustion, but the specific sensor design is such as to be highly stable, and not to require a reference gas. Because it operates at a high temperature and it contains platinum surfaces, the sensor will measure the "Net" oxygen after any combustible gases have been oxidized, and in fact would ignite a flammable mixture of gases. Hence it is NOT suitable for flammable gas measurements! Also, the thermal conductivity of the gas has to be similar to that of nitrogen. This means that it is not suitable for measuring oxygen in exotic background gases such as helium or Argon, or even pure CO₂. Gases that would decompose at high temperatures such as chlorinated hydrocarbons are equally unsuitable, and in fact can be dangerous because they can generate highly toxic products such as phosgene.

But for measuring oxygen in nitrogen or similar inert gas mixtures, it has no equal in terms of stability, reliability and cost.

The analyzer does five main things with the oxygen reading. It **calibrates** it, using the “Span” function.

It **displays** it on the LCD screen. It reports the reading on its “**Analog output**”, a 4-20mA current loop. It **alarms** – i.e. fires two relays - in response to whether the reading is greater than or less than either of the two “Alarm set points”. The alarm can be bypassed by pressing the “**Alarm Bypass**” button. It reports the reading as requested on its **digital** outputs, either via USB into a PC or via ModBus into a control system.

The front panel controls can be used to affect most of these functions, as long as the security setting (in the AMI User Interface) is set so as to allow it.

Calibrate (“Span”) the analyzer:

It is important to calibrate the analyzer so that the reading corresponds to the actual oxygen content of the gas. This kind of analyzer inherently has zero output in the absence of oxygen, so it is only necessary to “span” the analyzer by making its reading on a high oxygen level gas correspond with the actual oxygen content of that gas. For the standard analyzer (with a 0-25% maximum range) air is the ideal calibration gas. High range analyzers will need a calibration gas of concentration close to the maximum range, either 50% oxygen in nitrogen or 95% oxygen in nitrogen.

The analyzer is so stable that calibration only needs to be done once every six months or so, and even then it is mostly to check that the analyzer is still working correctly.

There are some considerations however that you need to be aware of. See the section below called “Spanning the Analyzer” (page 12) for details.

Reading display:

The oxygen reading is shown on the LCD screen. The analyzer automatically scales its reading so that the display shows the best resolution.

Analog output:

The analyzer has an isolated 4-20mA self-powered current loop output. This is the industry standard analog signal. 4mA flowing through the loop means that the reading is zero, while 20mA means that the reading is full scale. But what does full scale mean? This is what we call the “Output range”, the range over which the 4-20mA output is scaled. You can select from several possible output ranges by pressing the “Output Range” button, at which the LCD will show the full scale of the currently chosen output range. You can change this by pressing the up or down arrow buttons until the range says what you want. Only certain ranges are possible: for the standard analyzer they are 0-1%, 0-5%, 0-10% and 0-25%. The high range analyzers add 0-50% and 0-100%, although the maximum the analyzer can read is 95% due to the logarithmic response of the sensor, hence this unit is called a 95% unit. Whatever you select, the analyzer will scale the 4-20mA output over that range of values. When the arrow key is released the analyzer will store the new set point and revert to showing the oxygen reading.

Alarms:

The analyzer contains two relays with “Form C” contacts (technically a “common” contact, and one that is connected to the common when the relay is powered, and the other connected when the relay is unpowered) each of which can be set to change state when the oxygen level reaches a certain percentage of the output range. Typically they will be set so that the relay is powered when the unit is NOT in alarm, and to go into the unpowered, i.e. alarm state, when the oxygen level exceeds a certain value. This is what is called a high alarm (alarming when the reading goes high), and in the “Failsafe” mode, meaning that the relay indicates an alarm either when the reading is too high, or else when the power has failed. There are many logical possibilities for the relay operation but they are selected using the User Interface program and so are not described here. If the unit does go into an alarm the front panel LED will change color to red.

You can change the alarm set points using the “Alarm one” and the “Alarm two” buttons. When pressed, the LCD will show the current set point, and this can be changed by pressing the up or down arrows. When the arrow key is released the analyzer will store the new set point and revert to showing the oxygen reading.

Digital outputs:

The analyzer has both a USB connection and an RS485 connection on its back panel. The former can be used with the AMI User Interface program to make use of all the advanced features possessed by the analyzer, while the latter can be used to allow a control system to interact with the analyzer over ModBus. ModBus is an industry–standard communication protocol often used by such systems. AMI can supply a manual that gives details on how to use this.

Alarm Bypass:

If the unit goes into an alarm the alarm can be temporarily silenced or disabled by pressing the “Alarm Bypass” button. If the analyzer is not in alarm, pressing the button will cause the display to show the alarm bypass time in minutes. If the analyzer was indicating an alarm, pressing the button will cause it to be turned off and held off for the period of the alarm bypass time. If the alarms are programmed to latch, pressing this button will also unlatch them (and stop them from alarming again for the hold off period).

Spanning the Analyzer:

The analyzer features a “Span Factor” display to help you determine the state of the sensor. As the sensor ages, its output decreases very gradually, and therefore the span factor has to be turned up during calibration to compensate.

Press and release the UP button while the unit is showing its reading to view the span factor. The factor corresponds to the setting of a traditional ten turn span pot with a turns counter dial on it.

The setting should be between 300 and 600 for a new sensor. When you calibrate the analyzer, check this value before and after the calibration. You should see that the value will remain very stable for many years, and then goes up slowly. When this starts happening, it indicates that the sensor is reaching the end of its life and the unit should be returned for a replacement. Experience indicates that this is unlikely to happen for at least ten years.

Down button – Temperature reading:

If you press the DOWN arrow button the display will show the temperature of the analyzer in degrees Fahrenheit. The value is limited to 25F at the lowest, and about 120F at the highest. The analyzer is not sensitive to temperature changes within – or even far outside - this range.

Interconnections:

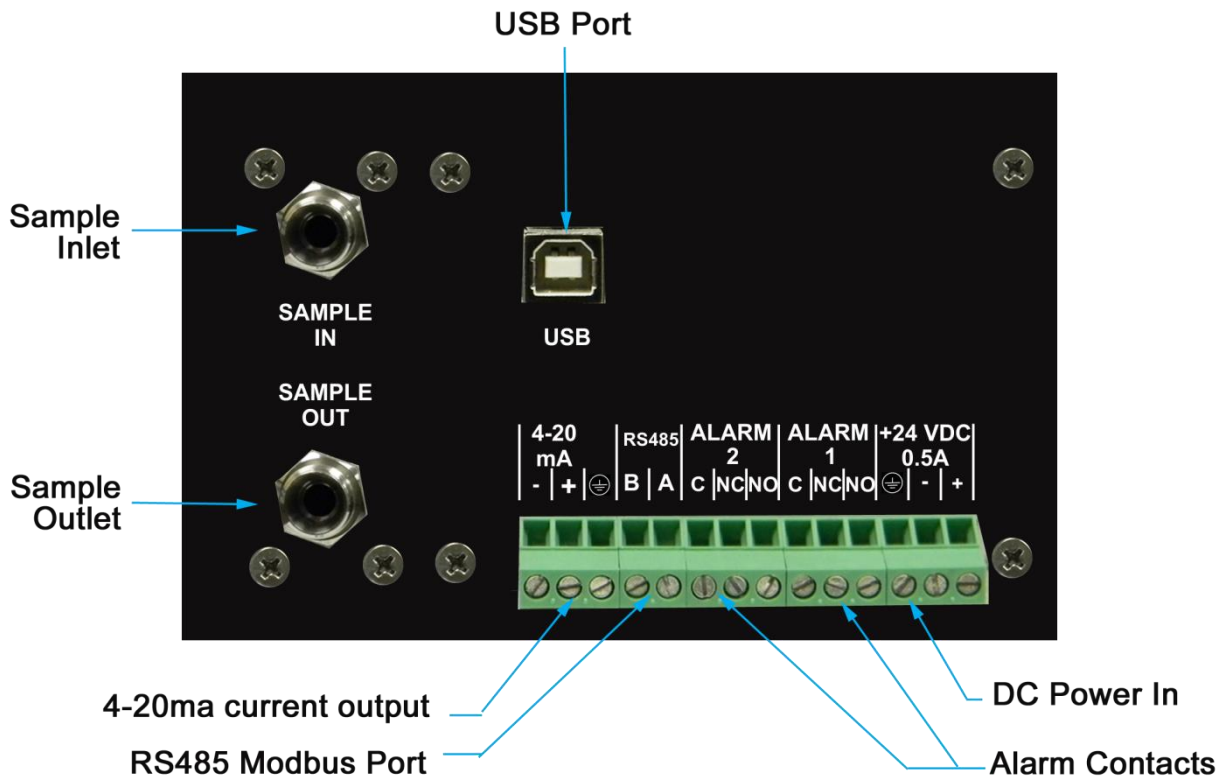

Figure 3. Back panel of the 70R1. Note: there is an alternative power supply connection on the right side of the analyzer as viewed from the back. Only use one power connection!

Alarm connections:

The alarm connections are single pole double throw relays, i.e. Form C contacts. They may be programmed to go into alarm mode either above or below a set point, to open (the normally closed) contacts or close them, and to either latch or not latch, that is, go back out of alarm when the oxygen level returns below (or above) the set point or else wait until the operator presses the “ALARM ACKNOWLEDGE” button on the front panel. The contacts can handle AC or DC voltages, and can carry up to 5A of current for a resistive load. Inductive loads such as solenoid valves should be “snubbed” – we suggest that you connect diodes or Zener diodes or “Transzorbs” directly across them to absorb the inductive spike. Do not connect them across the relay terminals on the analyzer, since the resultant current loop will transmit a lot of RFI that could upset sensitive devices nearby.

Output connections:

This unit is equipped with an isolated 4-20mA output. It is capable of driving a 600 Ohm load and will saturate at more than 125% of the nominal full scale range.

Using AMI software you can force the output to 4mA (zero output), 12mA (half scale) or 20mA (full scale), and calibrate these values so as to get the most accurate possible transfer of information to a recording or computing device. If you forget to reset them the unit will automatically return to its normal operation after ten minutes.

Serial connections:

The 70R1 provides two serial connections – a USB port that can talk to a standard PC running the AMI User Interface software, and an RS485 connection that supports the standard ModBus protocol. The unit detects the presence of a USB connection, and disables the RS485 connection if one is detected. This allows you to leave it connected to the RS485 loop while you configure it with the AMI program.

For details see the chapters below.

Sample Handling:

This analyzer expects to see a sample at a fairly low pressure, somewhere between 1 and 30psig. It contains an orifice that limits the flow over this range. Higher pressures should be regulated down to about 10psig for best performance. It is possible to remove the orifice in order to deal with very low positive pressures of a few inches of water – contact the factory for instructions on how to do this. Sub-atmospheric samples will need a suitable pump to drive the sample through the analyzer – AMI can provide such a pump as an accessory if desired.

The exhaust should be vented to atmosphere or to atmospheric pressure.

Maintenance and troubleshooting

Maintenance:

The model 70R1 is virtually maintenance free other than for periodic calibration.

Periodic Calibration:

The analyzer is quite remarkably stable in operation. You may find that a calibration interval of 6 months is satisfactory. Just to be safe we recommend that you at least check the calibration on a monthly basis.

Sensor Replacement:

User sensor replacement is not possible, and usually quite unnecessary. If the sensor does die, the whole unit should be returned to the factory for service.

Troubleshooting

All oxygen applications

Analyzer does not power up.

1. Check that the power is connected correctly, and the power supply is correctly plugged into the wall.

Analyzer reads too low

1. Sensor is not calibrated. Flow span gas through it and span the analyzer until the analyzer reads appropriately.
2. Your gas contains flammable material. Anything flammable will burn on the sensor, reducing the oxygen level by the amount of oxygen it takes to combust the material.
3. Your gas contains helium as the background. Do not use this analyzer with helium.
4. Your gas contains lots of low-thermal-conductivity gas like argon or CO₂. CO₂ will slightly reduce the readings at high concentrations, but at 100% the sensor will run too hot, shortening its life.

Analyzer reads too high

1. Your gas actually contains more oxygen than you think! This analyzer almost never reads too high.

Analyzer reads zero

1. Let the analyzer warm up for a while.
2. Contact AMI and discuss the internal variables with the technician (someone might have set things up incorrectly somehow).

No current output to recording device

1. Verify that the output wires are properly stripped and connected.
2. Verify the connections on the output terminal block.
3. Verify that the output connections are not shorted all the way back to the recording device. Disconnect the wires from the analyzer and use an ohmmeter to check for shorts or opens.

No output alarm indication

1. Verify the alarm set points are correct - press the appropriate switch on the front panel, and check the displayed reading on the LCD for correct setting.
2. Verify that the connections on the terminal block are properly stripped and correct.
3. Verify that the alarms are configured correctly, using a PC or similar communication device.
4. Verify the alarm delay time with the PC.

5. Verify that the output connections are not shorted all the way back to the recording device. Disconnect the wires from the analyzer and use an ohmmeter to check for shorts or opens.

Incorrect readings

1. If spanning on air, verify that the air source is free of water vapor (humid air will contain about 3% less oxygen than expected, depending on temperature), and that bottled air does actually contain 20.9% oxygen. Manufactured air often does not!
2. If using compressed air, make sure it is oil-free. Trace amounts of oil will burn on the sensor, reducing the oxygen level accordingly.

Analyzer refuses to accept front panel settings

1. Using the RS-232 interface, verify that the security is set the way you want it.

Still no correct operation

1. Call AMI at 714 848 5533, and ask for Technical assistance.
2. Or contact us by email at sales@amio2.com.

Specifications and Disclaimer

Specifications:

- **4 user selectable outputs:** 0-1%, 0-5%, 0-10% and 0-25% Optional ranges: 0-50% or 0-95%. The selection of an output range simultaneously controls the two alarms, the analog output and the datalogger so that all 4 functions operate on the same range.
- **Digital display:** 3 ½ digit LCD. Reads full scale from 0.00% to 25.0% independently of output range selection.
- **Alarms:** 2 fully adjustable oxygen concentration alarms. Dry contacts 3A. @24VDC/115VAC.
- **Analog output signals:** isolated 4-20mA. Represents the output range selected: 0-1%,0-5%, 0-10% and 25%.
- **Power requirements:** 10-28VDC <3 watts Supplied with a 115VAC to 12VDC adapter.
- **Minimum detection:** 0.05% of oxygen.
- **Repeatability:** +/- 0.1% of range or +/- 0.1% of oxygen, whichever is greater.
- **Operating temperature range:** 32°F to 122°F (0°C to 50°C).
- **Diurnal temperature specification:**< +/- 2 % of scale over temperature range.
- **Response times:** 90% full scale response times for specified range:0-25% <12 seconds; 0-95% < 12 seconds.
- **Long life zirconium oxide sensor:** 10 year life expectancy.
- **Area Classification:** Designed to meet General Purpose requirements.
- **Inlet gas pressure:** 1.0 to 30psig.
- **Gas connections:** ¼" 316 S.S. compression fittings.
- **Wetted parts:** 316 S.S. fittings and critical orifice,anodized aluminum cellblock.
- **Unaffected by changes in flow rate from 0.1 to 5.0 SCFH.**
- **Mounting:** panel mount.
- **Dimensions:** 6.5"W x 4.2"H x 3.0"D .
- **Weight:** 3 lbs.

To be installed only in installation (overvoltage) category I or II.

Disclaimer

Although every effort has been made to assure that the AMI analyzers meet all their performance specifications, AMI takes no responsibility for any losses incurred by reason of the failure of its analyzers or associated components. AMI's obligation is expressly limited to the analyzer itself.

The AMI analyzer is not designed as a primary safety device, that is to say it is not to be used as the primary means of assuring personnel safety. In particular it is not designed to act as a medical instrument, monitoring breathing air for correct oxygen concentration, and should not be used as such when it is the only safety device on the gas system.



AMI[®] WARRANTY & SUPPORT

LIMITED WARRANTY/DISCLAIMER

The warranty period is **TWO YEARS** for the Analyzer. Any failure of material or workmanship will be repaired free of charge for that specified period from the original purchase (shipping date) of the instrument. AMI will also pay for 1-way ground shipment back to the customer.

The warranty period for the electrochemical oxygen sensor is 6 months.

The warranty period for the electrochemical H₂S sensor is 6 months.

The warranty period for the zirconium oxide sensor is 2 years.

Any indication of abuse or tampering of the instrument will void the warranty.

Receiving the Analyzer

When you receive the instrument, check the package for evidence of damage and if any is found contact the shipper. Although every effort has been made to assure that the Analyzer meets all performance specifications, AMI takes no responsibility for any losses incurred by reason of the failure of this analyzer or associated components. AMI's obligation is expressly limited to the Analyzer itself.

EXCEPT FOR THE FOREGOING LIMITED WARRANTY, AMI MAKES NO WARRANTIES, EXPRESS, IMPLIED OR STATUTORY, AS TO THE NON-INFRINGEMENT OF THIRD-PARTY RIGHTS, MERCHANTABILITY, OR FITNESS FOR A PARTICULAR PURPOSE. IF APPLICABLE LAW REQUIRES ANY WARRANTIES WITH RESPECT TO THE SYSTEM, ALL SUCH WARRANTIES ARE LIMITED IN DURATION TO TWO (2) YEARS FROM THE DATE OF DELIVERY.

LIMITATION OF LIABILITY

IN NO EVENT WILL AMI BE LIABLE TO YOU FOR ANY SPECIAL DAMAGES, INCLUDING ANY LOST PROFITS, LOST SAVINGS, OR OTHER INCIDENTAL OR CONSEQUENTIAL DAMAGES, EVEN IF THE COMPANY HAS BEEN ADVISED OF THE POSSIBILITY OF SUCH DAMAGES, OR FOR ANY CLAIM BY ANY OTHER PARTY.

LIMITATION OF REMEDIES

AMI's entire liability and your exclusive remedy under the Limited Warranty (see above) shall be the replacement of any Analyzer that is returned to the Company and does not meet the Company's Limited Warranty.
